

estelon

from Alfred & Partners



*Designed
by Alfred Vassilkov*

Model Extreme Mk II

Serial Number _____

Your ESTELON loudspeakers have passed our quality control:

– Technical test passed.

Engineer, Estelon

– Listening test passed.

Alfred Vassilkov
Head of Research and Development, Estelon

Table of Contents

1. INTRODUCTION.....	4
1.1. ALFRED & PARTNERS OÜ.....	4
1.2. ESTELON EXTREME Mk II.....	6
1.2.1. Cabinet Design.....	7
1.2.2. Transducers.....	8
1.2.3. Crossovers.....	10
1.2.4. Connectors.....	11
1.2.5. Finish.....	11
2. SPECIFICATIONS.....	13
3. UNPACKING INSTRUCTIONS.....	14
4. SET-UP.....	22
4.1. INITIAL POSITIONING IN THE ROOM.....	22
4.2. SETTING UP THE SPEAKERS.....	23
4.3. INSTALLING THE SPIKES.....	25
4.4. WIRING.....	27
4.5. SETUP RECOMMENDATIONS BY ALFRED VASSILKOV.....	29
4.5.1. Troubleshooting.....	32
4.6. BREAK-IN PERIOD.....	33
5. TAKING CARE OF YOUR ESTELON SPEAKERS.....	33
6. ESTELON / ALFRED & PARTNERS OÜ – TECHNICAL SERVICES.....	34

1. INTRODUCTION

1.1. Alfred & Partners OÜ

Alfred & Partners, the Tallinn-based design studio, think-tank, and owner of Estelon, is not simply a business but a passionate dedication to a single, heartfelt idea: the development and manufacturing of instruments capable of unveiling the rich, emotional tapestry of music in a personally involving and captivating way.

For more than 35 years Electro-acoustics Engineer and company founder, Alfred Vassilkov, has been relentlessly designing loudspeakers. His designs have been awarded numerous patents while also achieving much success in Europe. In 2010 a decision was made: to establish his own brand based on his extensive experience, knowledge, and relentless passion.



Alfred Vassilkov, the Designer and Founder of Estelon

Such dedication carries the implicit responsibility of a wholly uncompromising approach to audio design. Pride of craftsmanship shares equal footing with sonic innovation. Alfred Vassilkov's visionary achievements along with his tireless drive and quest for musical truth created an innovative brand of loudspeakers whose products offer unrivalled musicality and incomparable beauty: Estelon. More importantly, Estelon offers a distinctive key that assists listeners in unlocking the vast structure of emotion through music.

For the Estelon brand, the visionary development started in 2006 when Alfred started analyzing materials and technologies for producing cabinets with streamlined shapes that could not only reproduce the best sound but also assimilate into home interiors with an elegant, sculptured look. Years of research and development led him to a proprietary, crushed marble-based composite. The material, having excellent stiffness and anti-resonant attributes, as well as various technical advantages, allows the creation of molded cabinets with a purposeful design that enhances the sound quality of the entire audio system. The unique cabinet shape of Estelon speakers create the ideal conditions for sound reproduction. Its curved, smooth form eliminates corner reflections. A sculpted narrowing of the area where high frequency emanates helps achieve 0 degrees phase at the listening position, while the cabinet's larger radiuses create controlled directivity of the propagating soundwaves. The cabinet then becomes wider and deeper at its base for both stability and to allow effective low-frequency reproduction.

Every loudspeaker produced must pass Alfred & Partners' extreme level of quality control. Each pair of loudspeakers is completely hand-built, painted, assembled, tuned, tested, and then listened to individually. All Estelon products are meticulously handmade in Estonia, to the company's exacting standards.

1.2. Estelon Extreme Mk II

Estelon Extreme Mk II: By elevating the act of listening to new heights, Estelon delivers an audio experience like no other. The system comprises an upper and a lower module, with the former fully adjustable to best suit a room's acoustic attributes and the listener's personal preferences.

Paramount among the physical design elements continues to be the use of the Estelon unique cabinet shape form. This form has been developed and perfected over a five-year period. Its design and construction allow it to easily couple with non-acoustically treated listening areas (i.e. normal living spaces). Premium quality components in separate chambers, state-of-the-art carbon-fiber resonant control, and applied isolation technology along with top-quality dampening materials, are all contributing factors to an exhilarating audio experience.

Many years have passed since the genesis of the Estelon, and much has been learned while embodying all achievements. The roots and choices have evolved into the Estelon sound. The refined combination of the selected drivers and the acoustical attributes of the enclosure has allowed Estelon to achieve their signature sound along with enhanced performance qualities.

The Extreme Mk II is a speaker designed for larger listening rooms [suggested room size 50-200 m² (530-2150 ft²)] and provides exceptionally wide imaging, deep sound stage, and thrilling life-like dynamics. It is far more than speaker. It is a genuine musical instrument in its own right, and when carefully integrated into a system and listening space, it is capable of connecting the listener to the music in a most profound and transcending way. Everything is expressed naturally, balanced, and emotionally engaging. The Extreme

Mk II possesses an eminently musical temperament that is immediately evident upon your first audition and every subsequent listening experience.

The Extreme Mk II provides defined and deep bass, clear and articulate mid-range, and musically detailed and dynamic high frequencies. The Extreme Mk II can reproduce the finest nuances of music.

1.2.1. Cabinet Design

The cabinet form has been developed and honed over many years of research and testing in order to find the right material that would allow the highest quality of cabinet and construction for the loudspeaker's acoustically engineered shape. The cabinet is extremely rigid, highly dense, resonant-free, and with exceptional internal dampening and acoustical control. This is the result of time-honoured construction techniques, a special casting process, the use of a proprietary marble-based composite along with the extensive use of sub-structural stiffening spars that break up resonance nodes and create an internal acoustic chamber of non-parallel sidewalls that is all but immune to unwanted standing waves that can cause a coloured sound. This is why the Estelon speakers reproduce a very natural and balanced sound.

During the final hand-assembly process each speaker is individually tuned to maintain uniformity from unit to unit. Each Extreme Mk II speaker weighs 250 kg (551.2 lbs.) in order to provide stability, and is constructed with two modules (upper and lower). The upper module of each loudspeaker is adjustable. Unusual in its defined form, the result of this cabinet construction allows the bass to roll effortlessly into the listening space.

1.2.2. Transducers

Each speaker has two woofers, one mid-woofer, one midrange and one tweeter. For the speaker to reproduce the full spectrum of sound with the absolute highest quality, a combination of four different driver types has been carefully chosen. These high-quality drivers are designed and produced by German driver manufacturer Thiel & Partner GmbH under the brand name Accuton and are revered globally as the best.

The two 250 mm (11") aluminium sandwich woofers have been designed together with the Accuton engineers, especially for the Estelon flagship loudspeakers. These drivers have an extremely stiff and lightweight membrane and very long linear excursion. In combination with the Cell concept motor system, where the voice coil is almost the same diameter as the whole membrane, these drivers in the Forza cabinet can reproduce a truly deep, accurate, and effortless bass. The Forza's bass has been said to sound like "live bass" This is a result of meticulous engineering.

The 250 mm (11") aluminium sandwich mid-woofer has also been co-developed together with the Accuton engineering team, with a unique motor system employing neodymium magnets to have higher sensitivity and suitable parameters for the Forza. Much like the woofers, this mid-woofer also has an extremely stiff and lightweight membrane that works in a high degree of piston-like behaviour well into the midrange. These characteristics enable it to produce accurate, free of colouration, and effortless explosive high bass.

The 168 mm (7") ceramic membrane midrange driver from Accuton employs a lightweight, extremely rigid, alpha-corundum membrane. In combination with the powerful, highly optimized Cell concept motor system, with neodymium magnet ring, the result is a highly efficient and transparent sounding midrange driver. Everything

from vocals to piano, strings, horns, and cymbals sound natural, accurate, fast and dynamic.

The 25 mm (1") chemical vapor-deposited diamond membrane tweeter from Accuton can reproduce sounds at the highest frequencies, up to 60 kHz, with no distortions in the human hearing range. Diamond is the hardest known material, with the highest speed of sound in any known material. This results in a perfect step response, while the first breakup modes occur way out of the human hearing range. The imaging precision, instrument spatiality, contours in 3D space and microdetail clarity produced by this tweeter is unmatched.

The sonic character of the Estelon loudspeakers that feature diamond tweeters is not what you would expect: an overly "brilliant" or "hard-as-diamond" sound, which in most cases is caused by a high amount of harmonic distortion. In our loudspeakers, through the properly designed crossover, the diamond tweeters simply disappear, and only the music remains. It is like being present at a live concert where one can hear the instruments but not the speakers reproducing the sound. The Estelon Diamond loudspeakers offer a new way of relaxed listening, and you get to sense all the details that you have never heard before on your old records and digital music. You will be immersed in acoustical spaces with a "live" 3D presence that was never there before.

Each drive unit is "broken-in" by running an audio signal through them for several hours before selecting matching drivers for each pair of speakers. When the drivers are in matching pairs, another "break-in" with an audio signal is conducted. Finally, drivers are fitted into the finished cabinet for individual tuning.

1.2.3. Crossovers

The crossover components have been chosen from among the absolute best available, with the synergy of the end result as a significant factor. All filter components are pre-measured and sorted to extremely tight tolerances before being used in the crossover production. To maintain the smallest of details in the audio signal we use direct wire connection between the components and point-to-point techniques. Everything is hand-soldered with high-quality solder, and with the shortest possible cable runs between drivers, crossover, and our custom connector. The internal cabling is of the highest quality and from the renowned cable manufacturer Kubala-Sosna.

The crossovers of the Extreme Mk II are designed to provide accurate time and frequency domain merging between drivers while preserving timbral and tonal accuracy. The crossovers are in their own isolated chamber to reduce the microphonic effects and vibration influence. Each crossover construction process involves careful attention from our engineers and designers, and each component is carefully tested to make sure that the result is impeccable. There is also an extensive critical listening and evaluation process done by our highly experienced engineers.

The crossover for the upper part drivers is located within the upper module to reduce the length of the filtered signal to the drivers, minimizing the signal loss. The upper module is supported by two custom stainless-steel spikes on the top and by a bearing ball on the bottom. Coupled like this, the vibration effects are minimized, and good rigidity has been maintained.

1.2.4. Connectors

The Extreme Mk II makes use of our latest development in connectors. Its custom connectors are built into the bottom of the loudspeaker. Instead of the typical binding posts which have screw-like construction, our new connectors are built like clamps. The construction resembles that of piano keys which are spring-loaded to hold the speaker cable attached. Under the spring-loaded key, there is a high-grade copper foil ribbon that is routed straight to the crossover above. All unnecessary metal-to-metal transitions are eliminated. There are no large dimension conductors that would enable degrading effects of circulating currents. Around the whole connector assembly, there are no metal parts and no dielectrics that would smear the sound. Only natural wood and pressed particle board are used for their dissipative and damping qualities. The result is purer, more airy and more articulated micro dynamics from bass to highs.

1.2.5. Finish

Just as in the making of a great musical instrument, the finish has also an influence on the outcome. Because of the highly sophisticated cabinet shape, all the processes in the finishing stage are hand-made with extreme care by highly experienced specialists using the best technology and procedures. After casting the proprietary marble-based composite, it is allowed to age. Then the preparation of the surface of the cabinet commences by hand sanding and by sealing layer upon layer through an elaborate and time-consuming procedure. Finally, the multiple coats of the lacquer finish are applied along with the final polishing to a mirror-like finish. The Estelon Extreme Mk II is

offered in a choice of dual tone liquid gloss finishes, or custom made premium finishes.

2. SPECIFICATIONS

TYPE:	4-way passive loudspeaker, bass reflex
DRIVERS:	
2 x Woofer:	250 mm (11") Accuton, CELL aluminum sandwich (custom design)
Mid-woofer:	250 mm (11") Accuton, CELL aluminum sandwich (custom design)
Mid-range:	168 mm (7") Accuton, CELL ceramic membrane
Tweeter:	25 mm (1") Accuton, diamond inverted dome
INTERNAL WIRING:	Kubala-Sosna
FREQUENCY RESPONSE:	25-60 000 Hz
POWER RATING:	500 Watts
NOMINAL IMPEDANCE:	3 Ω (min 2.0 Ω at 95 Hz)
SENSITIVITY:	91 dB / 2.83 V
MINIMAL AMPLIFIER POWER:	20 Watts
DIMENSIONS:	Height: 1770-2070 mm (69.7"-81.5") / adjustable Width: 690 mm (27.2") Depth: 820 mm (33.3")
NET WEIGHT:	250 kg (551 lbs.) per piece
SHIPPING WEIGHT:	300 kg (661 lbs.) per piece

3. UNPACKING INSTRUCTIONS

The packaging is precisely thought-through so despite the weight of 250 kg (551 lbs.) of each speaker, they can be safely transported to their final position in the room with the included lift cart which is a custom design for the Estelon Extreme Mk II model. The transport cases (industrial grade custom flight-cases) are equipped with wheels to ease the transportation and setup.

Your Estelon loudspeakers come packaged individually in 2 separate flight cases. We recommend keeping these cases for possible future transportation. The lift cart is packed in a separate cardboard box.

Due to the substantial weight and slippery surface of the loudspeakers, we suggest that at least four able-bodied individuals assist in the unpacking and positioning process.

Contents of the two flight cases:

- 2 loudspeakers
- 1 accessories box:
 - 1 user's manual
 - 1 Hex Wrench tool (size 10) for the safety bolt of the upper module of the speaker (plus extension)
 - 4 wire bridge connector
 - 2 x 2mm Allen key
 - 1 remote control
 - 2 power supplies
 - 4 pairs of gloves
 - 1 polishing cloth
 - 2 sets of spikes (8pcs)
- 1 cover plates box:
 - 2 x cover plates

For unpacking, please follow the instructions described below and as shown in the drawings.

1. Open the cardboard box of the lift cart and take all the parts out of the packaging.
2. Screw the handles on the lift cart as shown in drawing 1 (four screws).

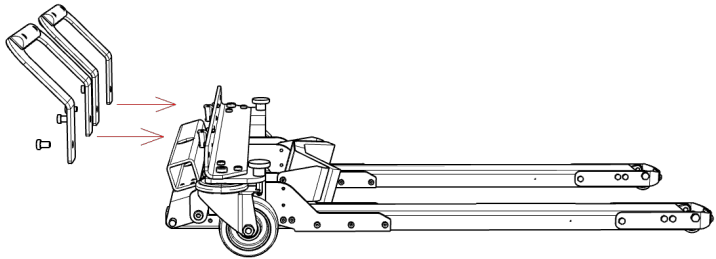

1

3. Now proceed with unlocking/opening all the locks of the speaker flight case cover while the flight case is in a horizontal position. (drawing 2)

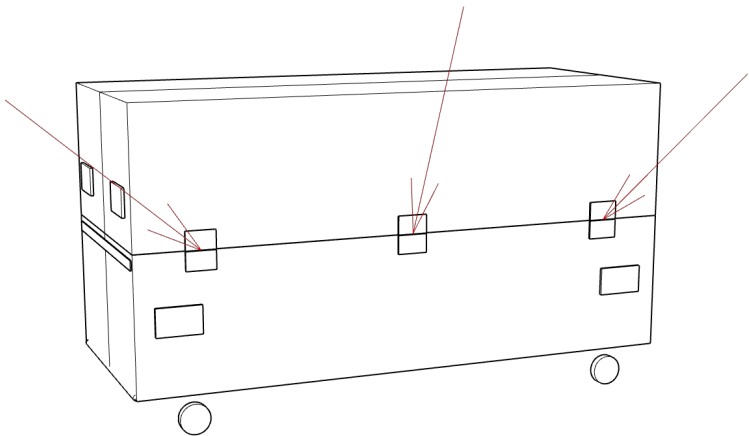

2

4. Carefully lift and remove the cover from the flight case. (drawing 3)

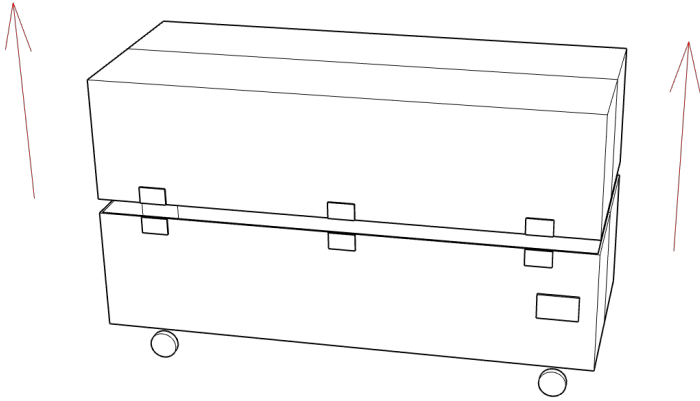

3

5. Remove the accessories box and the cover plates box from the flight case. (drawing 4)

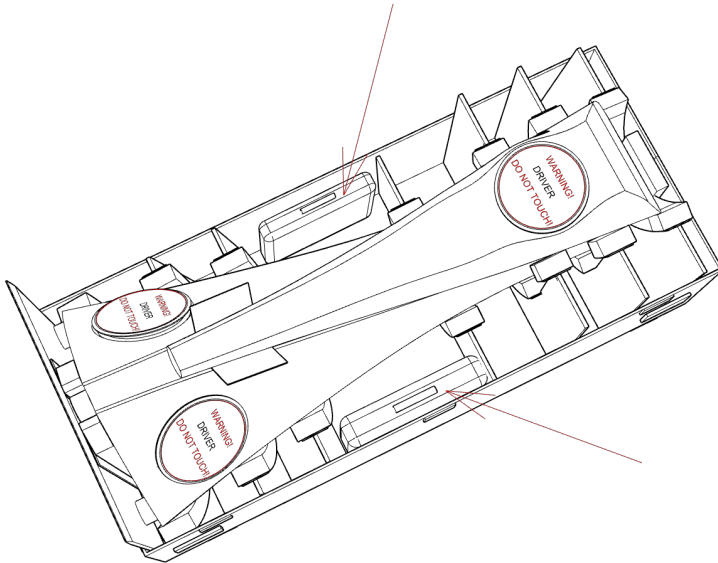

4

6. The three individuals can now lift gently the flight case with the use of handles on the flight case as shown in drawings 5 and 6, while the other person supports the speaker from the other side till it is in a vertical position.

NB! Do not touch the drivers while supporting the speaker.

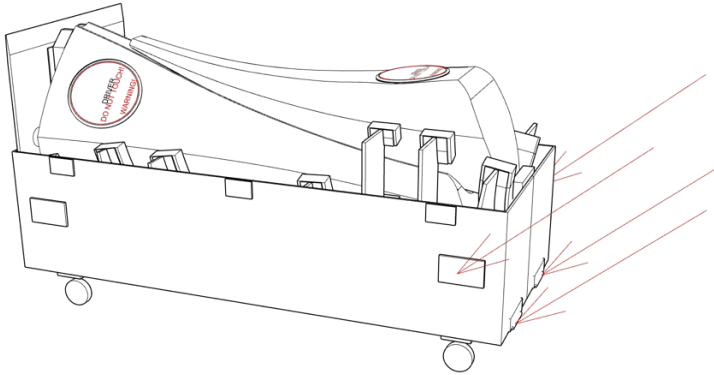

5

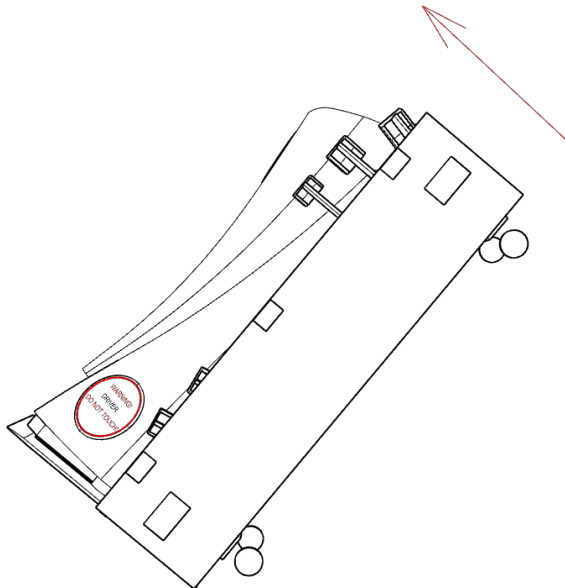

6

7. Now bring the lift cart and push it carefully under the speaker until the forks are all the way to the back, and the front part of the speaker touches the lift cart. (drawing 7)

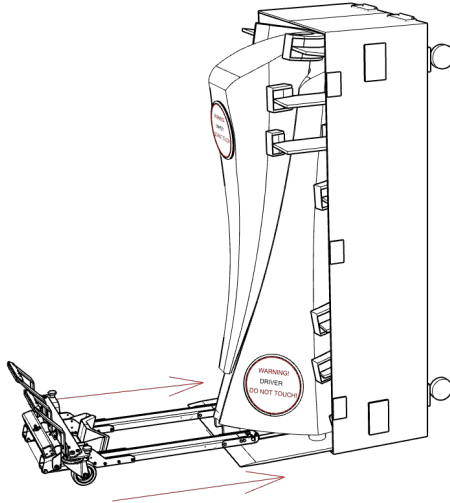

7

8. Take the hand lever and insert it into the lift cart. Then turn it 90 degrees clockwise, as shown in drawing 8.

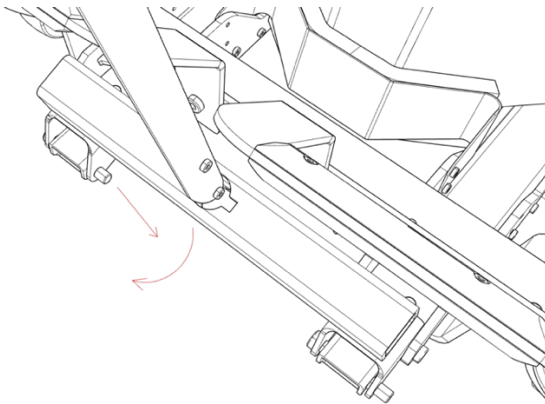

8

9. Pull the lever down so that the forks lift the speaker. (drawing 9)

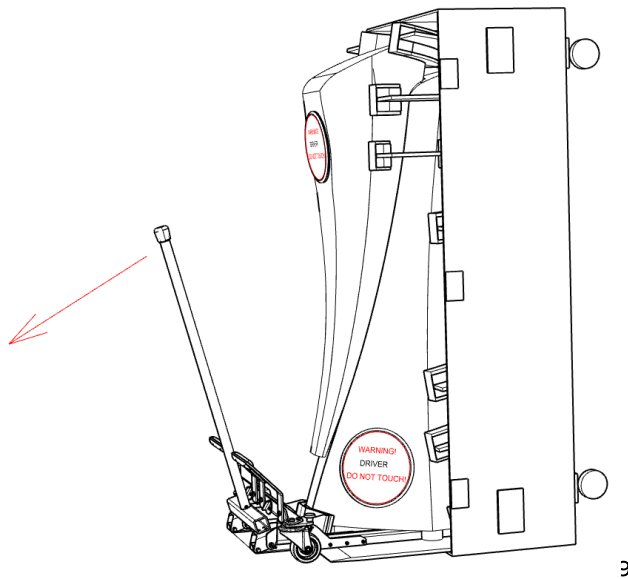

10. Then make sure that the safety valves are in the notches. (drawing 10)

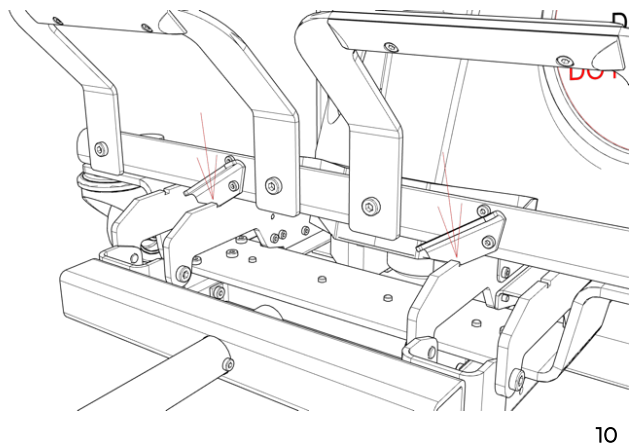

11. Remove the lever by turning it anti-clockwise and pulling it out. (drawing 11)

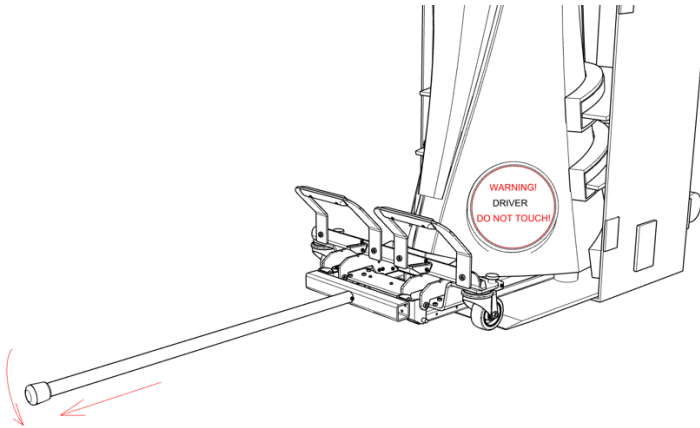

11

12. Transport the speaker to the desired location by moving the lift cart through the handles. One or two persons should support the speaker while moving it.
13. Once the speaker is at the desired position, insert the hand lever to the cart lift and turn it 90 degrees clockwise, as shown in drawing 12.

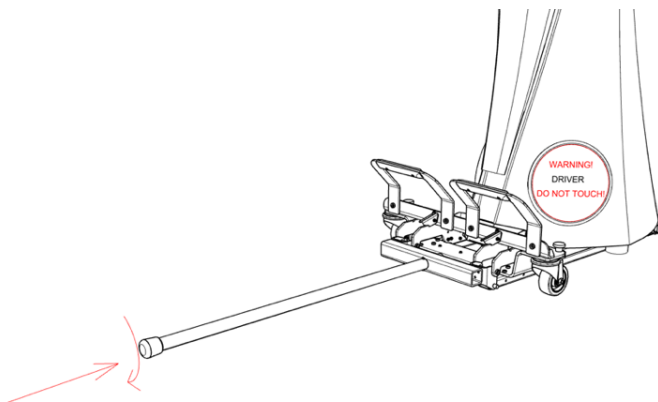

12

14. Unlock the safety valves. (drawing 13)

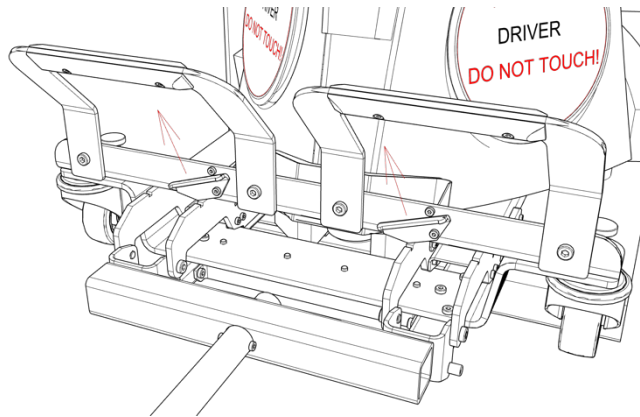

13

15. Lift the lever so the lift cart forks release the speaker. (drawing 14)

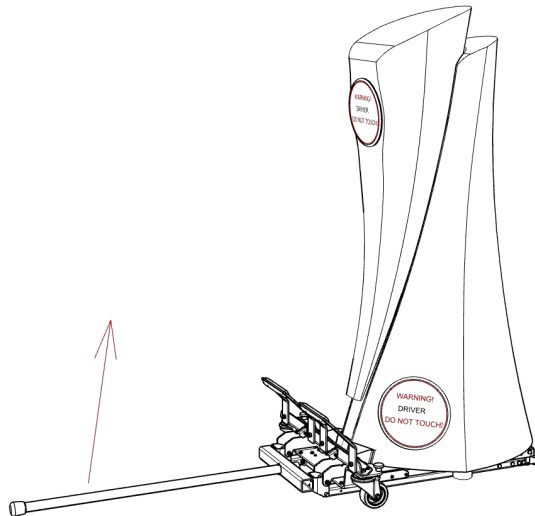

14

16. Remove the lift cart and repeat the process for the other speaker.

17. Carefully remove the protective foam plate that is placed between the 2 speaker modules as shown in drawing 15, and then remove the cloth bag of the speaker by starting with the upper module and by pulling down the bottom part of the cloth from the edge, as shown in drawing 15.

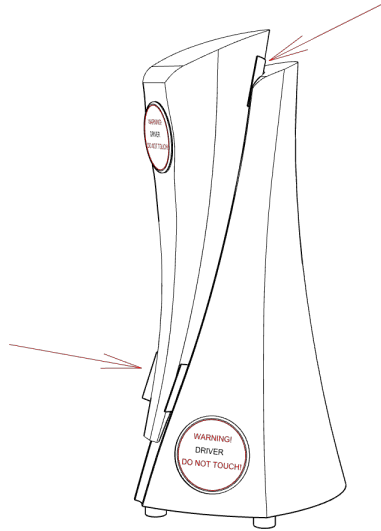

15

4. SET-UP

4.1. Initial positioning in the room

Model Extreme Mk II – Suggested room size 50-200 m² (530-2150 ft²)

When positioning the speakers in your room, it is advised to allow enough "free" space around the speakers to minimize sound reflections from walls, furniture, etc. This will contribute to achieving

correct tonality, realistic imaging, focus, and dynamics. The recommended minimum distance between the speaker and the nearest reflection point is 1.2 m (3.6 ft). The distance between the front wall and the speaker should be no less than 1 m (3.3 ft). The distance of the tweeter to the front and side walls should not be the same.

Listening point: the distance between the floor and your ears should be approx. 1 m (3 ft), while the distance between the listener and the speakers should be similar to the distance between the two speakers.

The positioning of the speakers in the room must be symmetrical for achieving a balanced sound stage. This is particularly important in a narrow space. The distance between the speakers should be approx. 2.5 – 4 m (8.2 – 13 ft), depending on the size of the room and its reverberation characteristics. The recommended speaker's direction is approx. 7°, off-axis, towards the listening position (depending on the room acoustics).

Please contact your dealer for consultation on how to improve your room acoustics.

4.2. Setting up the speakers

Once you have positioned the speakers in the desired locations, it's time to release the upper module so it can be supported on the internal spikes and rollerball.

With the use of the Hex Wrench tool (size 10), loosen up the safety bolt which will allow the movement of the upper module. The safety bolt is located on the backside of the speakers on the top part of the lower module. It will require 4-6 anti-clockwise turns. (drawing 16)

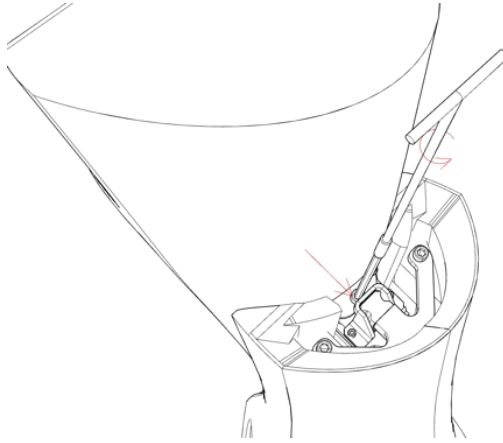

16

Now take the cover plates from the cover plates box and place them on the upper part of the lower modules as shown in drawing 17. They will attach magnetically.

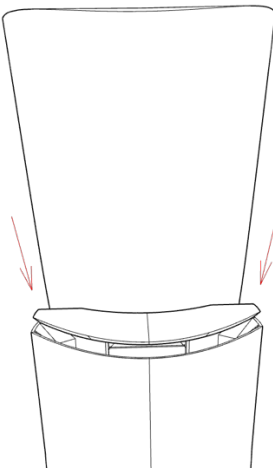

17

The next step is to connect the power supplies that you can find in the accessories box, to the DC sockets on the connectors' panels of the speakers. (drawing 18)

NB! First, connect the jack end on the DC socket and then the plug into the room's socket.

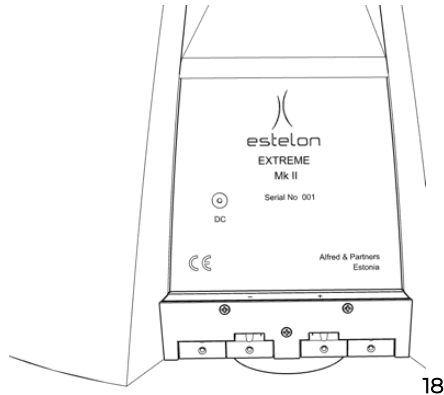

4.3. Installing the spikes

When using the speakers on carpeted flooring, use the **spikes** in order to pierce through the carpet to the hard flooring underneath. Here are the instructions for installing the spikes:

1. Use the lift cart to lift the speaker. Leave 125 mm (4,9") free space between the front part of the speaker and the lift cart. Then place a base spacer under each isolation foot as shown in drawing 19.

NB! Make sure you place 4 base spacers under the speaker's isolation feet (1 base spacer under each foot).

The base spacers can be found in the lift cart box.

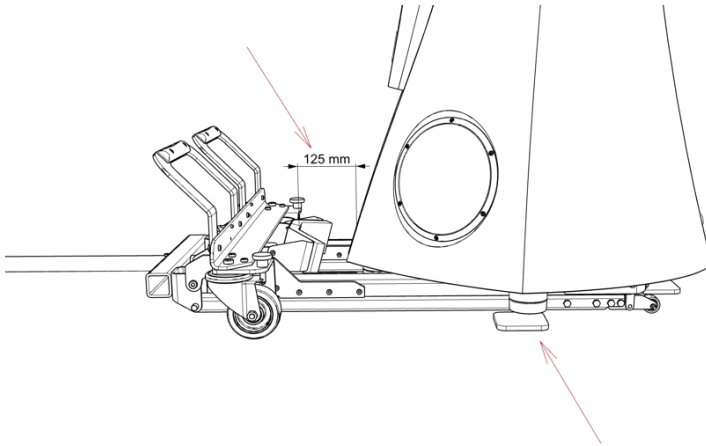

19

2. Lower the speaker and pull out the lift cart.
3. Now place the 2 long spacers on the lift cart forks. (drawing 20)
The long spacers can be found in the lift cart box.

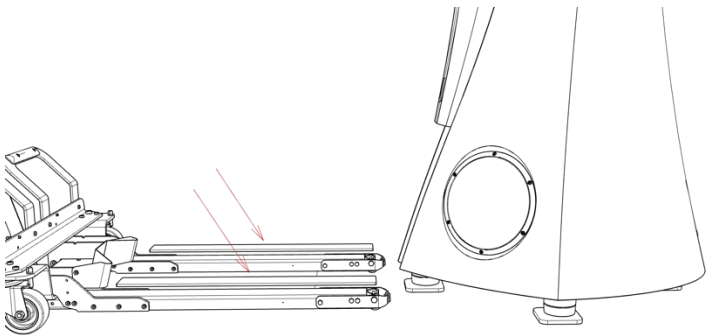

20

4. Lift the speaker again making sure that the lift cart has 125 mm (4,9") free space from the front part of the speaker. Remove the base spacers and screw in the spikes as shown in drawing 21.

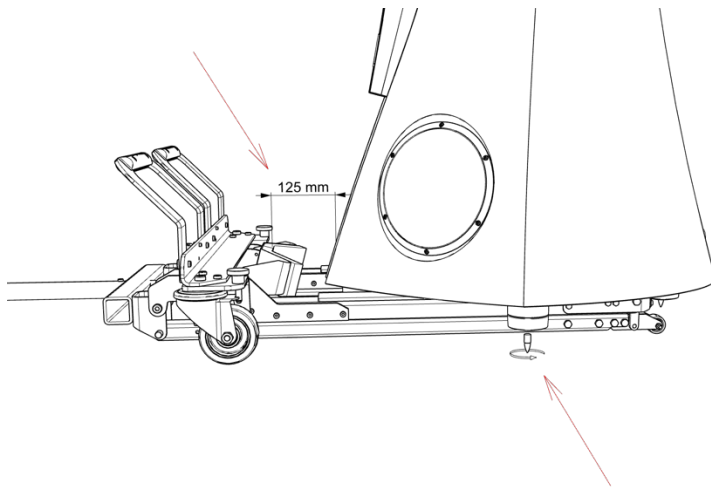

21

5. Repeat this process for the other loudspeaker until both loudspeakers

In case of an uneven floor, unscrew the spike or the isolation foot that does not touch the floor firmly.

NB! Do not tilt the speaker to reach the spike or isolation foot that requires unscrewing.

Proper use of the bases and spikes will achieve accurate audio reproduction with fast and deep bass, focused imaging, and avoiding colouration in the midrange frequencies.

4.4. Wiring

The Extreme Mk II model has the capability of using a 2-wire connector bridge, which is the default (drawing 19), and a 4-wire connector bridge for when connecting 2 amplifier channels. (drawing 20)



19



20

In order to exchange the 2-wire connector bridge, with the 4-wire connector bridge which is included in the accessories box, you will need to remove the 3 screws of the attached bridge connector with the use of a PH1 tip screwdriver (not included) and replace it with the 4-wire bridge connector.

Our proprietary connectors accept banana, fork, or bare wire termination. The connector can be opened with the supplied Allen key, size 2mm which is provided in the accessories box, by inserting the Allen key into the connector key hole and pressing down. Then insert the cable termination and just release the connector key. (drawing 21)

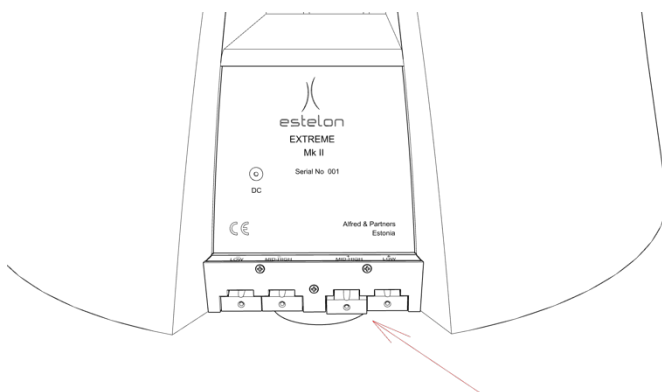

21

NB! When connecting the speaker to the amplifier please make sure that the amplifier is in the off position. Connect the speaker cable to

the pole terminal on the back of the speaker: speaker terminal „+“ with the amplifier terminal „+“ and „-“ with „-“. For signal flow, please follow the direction marked on the cable or in the cable manufacturer's instructions. Typically, the signal flow is in the same direction as the labelling/writing on the cable.

4.5. Setup recommendations by Alfred Vassilkov

The set-up of the sound consists of the balance between different parameters such as tonality, bass accuracy, focus, stage imaging, depth, etc. The time required for this process depends on the listener's experience and skills. Proper setup will maximize the speakers' performance.

The upper module of each loudspeaker is adjustable in the range of 300 mm in height. To make the positioning process more convenient we set nine different steps in this range, so the top module of the speakers can be moved up or down. For this process, both speakers are connected to a controller box and the height of both speakers can be changed simultaneously with the dedicated remote control. (drawing 22)

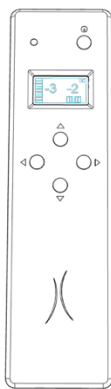

22

This adjustment process is crucial in setting up the loudspeakers. The upper module has a curved front panel. Combined with the Cell concept drivers, the time alignment in the listening position is preserved. The motion of the upper module follows a curved trajectory, helping to maintain focus on the desired height.

Switch on the remote control by pressing the power button for at least 2 seconds. On the top right corner of the remote control screen, you will see 2 dots indicating the left and right speakers. Once both speakers are connected over Bluetooth, the 2 dots will be lit. On the left side of the remote control screen, there is a vertical bar graph indicating the speakers' upper module's height position (9 positions ranging from 0 to +/-4). The height can be adjusted with the up/down arrows of the remote control. On the bottom right side of the screen, there is a horizontal bar graph indicating the tweeters' depth position (5 positions ranging from 0 to +/-2). The depth can be adjusted with the left/right arrows of the remote control. (drawing 23)

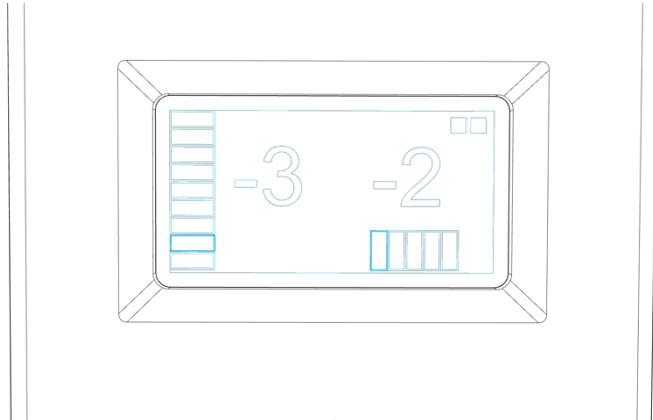

23

The upper module height adjustment is for achieving ultimate sound reproduction according to the room size and listening

position distance. When the listening position is closer to the speakers then the speakers' upper modules should be in lower position. In bigger rooms, the speakers' upper modules should be in higher position.

The tweeter adjustment modifies the focus point height in the listening position. The lower the sitting position is, the deeper in the cabinet the tweeter should be (minus range in the positions points). As a starting point when setting up the speakers, the height of the upper modules and the depth of the tweeters should be in the middle positions (the tweeters should be centered by default).

NB! The listener's experience is crucial in adjusting the speakers' upper modules and tweeters positions. In addition, each room has its own characteristics, therefore please refer to the above suggestions as general guidelines.

During the final set-up, small adjustments may be made to the initial chosen position, e.g. moving the speakers 10 cm towards the front wall, etc. Please evaluate the sound carefully every time you make a small change in the positioning. Continue making small changes in the positioning and evaluate again until the proper position with a balanced, natural sound is found. We suggest that you test and listen to various musical pieces from different genres to avoid specific sonic accents.

NB! For the small adjustments in positioning use the lift cart.

Before critical listening, please allow 60-90 minutes of playback for system stabilization. When listening at an excessive volume you risk damaging the drivers.

NB! When the sound is set up, please remove the power supplies so there's no electromagnetic interference.

4.5.1. Troubleshooting

When the speakers are not detected by the remote control, or when there is a lack of functionality while adjusting the upper modules and the tweeters, then reset the remote control by holding down the left and right arrows simultaneously for 5 seconds. The remote control will restart and will connect with the 2 speakers. If resetting the remote doesn't fix the issue, then remove the DC power supply from the speaker and connect again. Then reset the remote control again.

If the remote control cannot connect with the speakers due to a malfunction and the height of the upper module needs adjustment, there is an alternative manual process. There is a switch inside the speaker cabinet which can be accessed through the magnetically attached cover plate which is located on the top part of the lower module. (drawing 24)

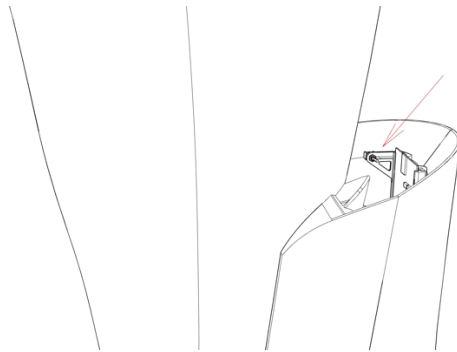

24

When pressing the switch up, the upper module of the speaker will move up, and when pressing the switch down, the upper module of the speaker will move down.

4.6. Break-in period

Although all Estelon speakers have an initial “break-in” at the factory, due to shipping conditions and pressure/temperature changes that may have been incurred, the speakers will need to go through an additional “break-in” process before their final set-up. All the mechanical and electrical connections will stabilize naturally after playing a continuous music signal for approx. 24 hours – e.g. use a digital source on repeat mode. After the initial “break-in” period, you can start setting up the sound according to Alfred Vassilkov’s recommendations. Please note that the speakers should reach their optimum level of performance after about 300-400 hours of use.

5. TAKING CARE OF YOUR ESTELON SPEAKERS

The multi-coated finish applied to Estelon speakers is considered the most advanced automotive finish available. It is extremely strong and durable. In order to maintain the speakers’ immaculate appearance, special cleaning cloths are provided with your Estelon loudspeakers. Please note that only dry cleaning is allowed. Do not wash the speakers. In case of a smudge/spot, please use a damp, soft, lint-free cloth to clean the smudges before the final finishing with the special cloths that accompany the speakers. For the Liquid Gloss finish, please use only the polishing cloth included in the flight case. Please do not apply polishing to the speaker drivers. The use of other materials can damage, scratch, or destroy the finish.

Additional information regarding the polishing cloths and other products:

For all finishes:

- Use with the provided microfiber cloth: Würth Active Glass Cleaner (Item # 089025) Silicone-free

- 3M Perfect-It III High Performance Polishing Cloth (Item # 50486) or any 3M Microfiber cloths

For Liquid Gloss finish only:

- Window Cleaner (with alcohol)
- Polish cloth impregnated with Krytox® (DO NOT USE FOR MATTE FINISH)

No additional wax or polish is required.

For additional information and guidance regarding cleaning/polishing materials, please contact your dealer or distributor.

6. ESTELON / ALFRED & PARTNERS OÜ – Technical Services

Alfred & Partners OÜ Five Year Limited Warranty

Terms and Conditions

1. Limited Warranty – All ESTELON products purchased from authorized ESTELON dealers are covered by a limited 5-year non-transferrable warranty granted by Alfred & Partners OÜ. This warranty includes all parts and labour charges as well as return shipping charges (product owner is responsible for all shipping and insurance charges one-way to the ESTELON repair facility or ESTELON factory approved repair facility).

Alfred & Partners OÜ warrants the purchased product to be free from manufacturing, materials, and workmanship defects for **five years** from the date of original purchase, subject to the following conditions.

Customers should consult with their original ESTELON dealer or distributor for possible alternate repair instructions prior to contacting the ESTELON factory. Other ESTELON dealers or distributors may refuse from assisting the Customer under the limited warranty. BUT under any and all circumstances customers are welcome to contact our sales department, listed on our website www.estelon.com, for service assistance.

This limited warranty is valid only in the country where the product was originally purchased. If the repair request that is covered under this warranty comes from another country, then Alfred & Partners OÜ may request the Customer to compensate Alfred & Partners OÜ additional costs arising from providing this limited warranty in another country than the country of original purchase.

This limited warranty shall not affect the statutory rights of the Customer.

2. Limited to Original Purchaser – This warranty is for the sole benefit of the original purchaser of the covered product and may not be transferred to a subsequent purchaser of the product.

3. Conditions and Limitations – This warranty is subject to certain conditions and limitations, as follows. This warranty is void and inapplicable if the product has not been used in accordance with the instructions found elsewhere in the owner's manual, or if it has been misused or abused, damaged by accident or neglect, or in transport once in possession of the purchaser. The warranty is also deemed void if the product has been repaired, modified, or tampered with by anyone other than Alfred & Partners OÜ or its specifically authorized agents. Please Note – if the fasteners to the cover of the crossover area, those covered with multi-coloured specialty epoxy seal, have been tampered with / the epoxy removed – the warranty will be considered to be void.

This warranty does not cover defects due to accidents or similar causes arising after the risk for the product has passed to the Customer, or normal deterioration, wear and tear.

4. Remedy – If this product contains a material, manufacturing, or workmanship defect that cannot be repaired at the dealership where the product was purchased, it must be packed in original packaging and returned to Alfred & Partners OÜ via insured freight, at the owner's expense. If replacement packaging materials are required, they may be purchased from the factory at a charge. **Returned products must be accompanied by a written description of the defect, and a return authorization number (available from the factory via phone or email).**

Upon receipt of a defective product, Alfred & Partners OÜ agrees to repair the product without charge for parts or labour. The product will then be returned via prepaid, insured freight, with the carrier at the sole determination of Alfred & Partners OÜ. This constitutes the purchaser's sole remedy.

Alfred & Partners OÜ undertakes during the warranty period to the exclusion of any other remedy to repair or replace the part of the product, which the examination by Alfred & Partners OÜ shows to have been defective. The warranty period for repaired or replaced parts shall not exceed the original warranty period and shall terminate along with the original warranty. The term of the original warranty shall not be extended by the duration of any warranty repairs.

5. Design Changes – ESTELON reserves the right to modify its products or change specifications at any time without obligation or liability to previous purchasers.

6. Miscellaneous – This warranty does not extend to any incidental or consequential costs or damages to the purchaser. This

warranty gives you specific legal rights. You may also have other rights which vary from country to country.

Instructions for Obtaining Repair Service

1. Complete the Return Authorization Request Form – available online at estelon.com/support.
2. Upon clicking the 'Submit' button on the Return Authorization Form, the ESTELON factory will review it for completeness and return an e-mail to you with an RA number when required (please allow 2-5 days for a return e-mail).
3. Crate and/or package the product **in its ORIGINAL FLIGHT CASE CONTAINERS ONLY**, according to the instructions included in the return e-mail, and ship the product to the shipping address included in the e-mail. The owner is responsible for paying the shipping and insurance charges (Alfred & Partners OÜ will cover return shipping and insurance charges on warranty repairs).
4. **In the case of non-warranty repairs**, Alfred & Partners OÜ will physically inspect the product and contact the customer for repair approval. Upon approval and completion of the repair, the product owner will be informed of the final charges (including return shipping). Payment may be made by bank/wire transfer prior to the final shipment). Payments not received within 30 days of initial contact may incur storage fees.

We strongly recommend that all product repairs should be conducted through the ESTELON factory or an authorized ESTELON repair facility. ESTELON products are designed and manufactured to the highest tolerances with numerous hand-picked components; for this reason, we HIGHLY RECOMMEND that components not be serviced by non-authorized repair facilities. Alfred & Partners OÜ values its loyal customers and will make every attempt to return repaired

products to their original factory specifications. Customers should consult with their original ESTELON dealer or distributor for possible alternate repair instructions prior to contacting the ESTELON factory. BUT under any and all circumstances customers are welcome to contact our sales department, as listed on our website www.estelon.com, for service assistance. All non-warranty repairs are warranted for one year from the date of the return shipment.

Have we answered all your questions?

*If not, please send us an email with your questions at
sales@estelon.com*

www.estelon.com

ESTELON is a trademark of Alfred & Partners OÜ

Alfred & Partners OÜ

Kukermiidi 6

Tallinn, 11216

Estonia

Notes